



Particulate Monitoring Systems

Continuous Measuring System
for Stack Particulate Emissions

DT990

Particulate Emissions

Monitoring System



Certificate No: 9389

- Advanced unique sensor design includes zero, span and unique contamination checks
- Powerful and advanced graphic and user interface screens
- Upgradeable to include control for up to 32 sensors plus additional 32 calculated channels (eg Mass, mg/Nm^3)
- Electrodynamic measurement with Digital Signal Processing giving high accuracy measurement
- Full data recording for process analysis and legislative compliance
- PC reporting, graphing and data analysis software (optional)

applications

Principle of Operation

The DT990 combines advanced signal processing techniques with PCME's unique Electrodynamic measurement principal. When the sensing probe is installed in the duct or stack, particles in the airstream interact with the sensing rod and a charge induction effect is analysed in the probe. Distributions in the particle stream result in a frequency charge induction response, which is directly proportional to the concentration of particulate (application dependant). The instrument's output is an analysis of this frequency response and can be calibrated in mg/m^3 by comparison to reference iso-kinetic sample results. This technique has achieved ISO 10155, MCERTS & TUV approval.

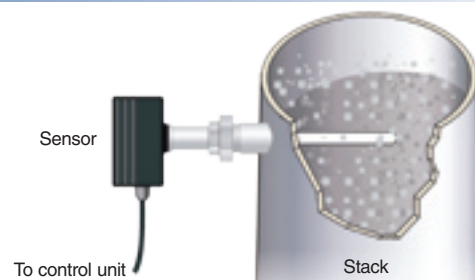

Advanced Design

Unlike Triboelectric systems, the Electrodynamic measurement is not significantly affected by velocity variations between 8m/s and 20m/s and is not affected by build up on the rod surface. The DT990 is, therefore, suitable for emission measurement in the most aggressive environments including those stacks with variable velocity.

In addition, PCME's Electrodynamic technique enables the use of patented fully insulated probes, essential for high humidity gas streams and applications with high conductive dust loadings. Very low concentrations ($<0.01\text{mg/m}^3$) can be measured due to this unique measurement principal. Automatic gain controls allow the system to optimise its response to varying dust levels e.g. pulsing bagfilters

Features include:

- Normalisation for T and O_2 *
- Broken Bag diagnostics for pulse cleaned Bagfilters
- Mass calculation (kg/year) capability for both fixed and varying velocity applications (varying velocity requires velocity input)

* Assumes input from appropriate monitor

Advanced Sensor Features

Advanced probe and quality assurance checks

The DT990 includes the most advanced automatic functionality checks available on any probe system to provide full regulatory compatibility. The unique contamination circuit monitors for any leakage currents or signals across the insulator, hence providing the ultimate proof that the sensors measurement integrity is uncompromised. The automatic zero and span checks then provide proof that the electronic amplification and conditioning of the signal is performed within pre-defined tolerances. The above features form part of World-Wide Patents.

Automatic self-checks

- Zero Check
- Contamination Check
- Span Check

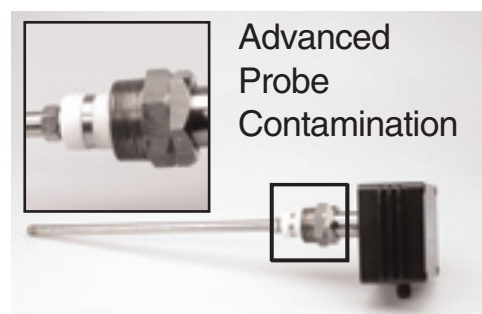

Applications

Particularly suitable for bag filter, cartridge filter, dust collector and cyclone applications.

Enhanced measurement accuracy

Advanced signal processing techniques are used within the sensor electronics to provide the following measurement features:

- Rapid Dynamic Ranging of 10,000: 1 (Dynatrack) permitting bag cleaning pulses to be accurately monitored while maintaining high accuracy in background emission measurement
- Rolling digital average calculations for accurate emission reporting



PC Based DustReporter 2 Software (optional)

Analysis and Historical Reporting:

- Automatic* or user controlled transfer of data from control unit's internal dataloggers to PC for further analysis and reporting
- Pre-configured and user configurable environmental report formats to satisfy legislation
- Easy access to historical data and alarm logs
- "Zoom" function permits data to be viewed rapidly and concisely for analysis
- Windows 95, 98, 2000, XP and NT compatible
- Mass emission reports
- On-Line alarm overview and graphs from various sensors displayed on PC screen*
- Bagfailure location*
- Real-time alarm overview

* Optional features

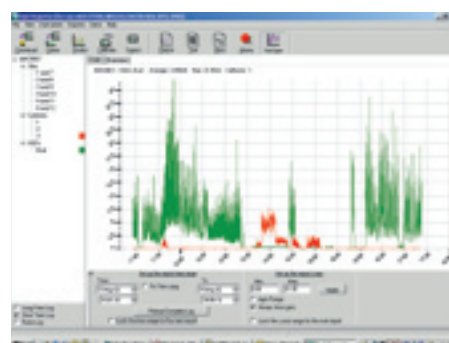

Typical Emission Graph

product features

System Layout

The instrument design permits up to 32 sensors to be connected to a single central control unit. The control unit provides power for the sensors (additional Power Supply Units (PSU) required on larger systems) and industry standard outputs (4-20mA, RS232/RS485 Modbus) are provided for easy connection to plant control systems. The control unit also comprises a powerful data logging capability to permit process and regulatory reporting. In addition, filter failure detectors (220 sensor for alarm detection only) can be connected to the control unit.

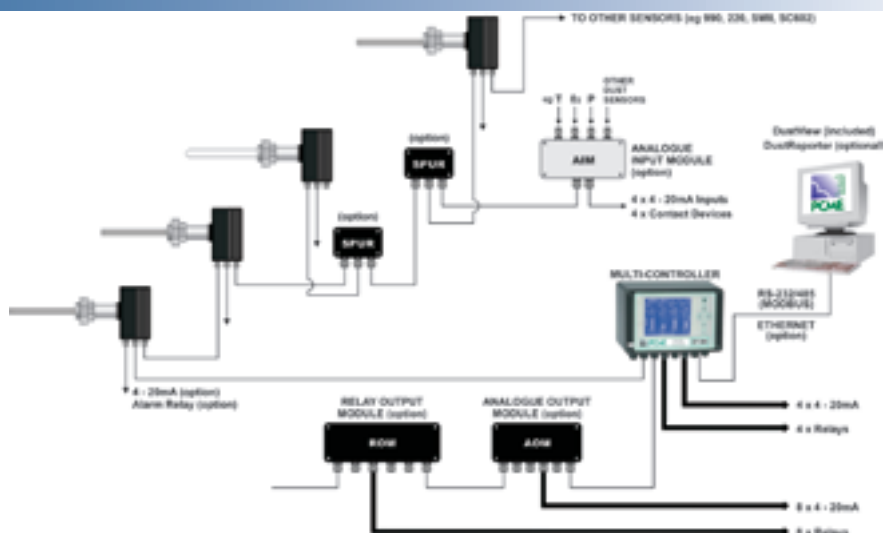

Control Unit Features



- Displays instantaneous and average emissions (bargraph, text and on-line graph)
- Customisable 'channel grouping' screen for displaying related data e.g. dust, velocity, O₂*
- Icon and multilingual user interface
- Monitors data from external sensors* for normalisation and centralised analysis e.g. velocity, O₂, Temp etc.
- Status screen for concise display of alarm conditions
- Controls up to 32 sensors
- Dual alarm levels with alarm delays
- Alarm log for instrument and emission alarms



- Full on instrument review of three simultaneous memories (Long Term, Short Term and Pulse see below)
- Windows software to download to PC for reporting (option)
- Large back-lit graphical display (320 x 240 pixels) for easy interpretation of graphical data
- Fully calibratable in mg/m³ (when calibrated against recommended ISO tests)
- QA screen allowing full overview of current condition of system. i.e. zero, span, probe contamination, comms.
- Multiple calibration factors
- Multi-channel bargraph shows emissions relative to alarms
- Permits easy comparison between emission sources
- Password protection



* Requires optional AIM unit(s)

Control Unit

Multichannel support:	1 to 32 sensors
Enclosure rating:	IP65
Enclosure Size (mm):	260w x 160h x 90d
Power Supply:	90 to 260 VAC (50/60Hz)
Current Rating:	250mA
Display Type:	Backlit LCD providing graphical and text display

4 x Isolated 4-20mA Outputs	Assignable to any channel
MODBUS RS485 & RS232 Outputs	Connection to PC or PLC
4 x Relay Outputs	Configurable and assignable
4 x Digital Inputs	e.g Plant on/off bagfilter cleaning pulse, multiple calibrations

Note: Local 4 - 20mA and Relay output also available from each sensor (option) and from output extension module (option)

Simultaneous maintenance, control and reporting

Control Unit Memory Type	Order Code	Purpose	Storage Rate/ Capacity	Typical Log Period for 8 Sensors
Long Term	L	Calculating Emission Averages (for reporting)	1 min - 2 hours, 150k entries	204 Days (@ 15 minutes)
Short Term	S	Visibility to Process Trends	1 sec - 4 mins, 20k entries	20 hours (@ 30 seconds)
Pulse	P	Locating Broken Bags	Optimised (13k entries)	25 minutes
Alarm Log	A	Log of all alarms	Instantaneous	1000 entries

specifications

Sensors

Probe Type Standard Insulated (optional*)	316 Stainless Steel Totally Insulated Sensor PTFE up to 250°C Ceramic up to 800°C
Stack Diameter (mm)	Standard Probes for up to 3m Cross Stack Probes for up to 6m
Temperature Range (flue gas)	Up to 250°C (standard) Up to 400°C (optional) Up to 800°C (optional)

*probe contamination check not available

Local Outputs - standard - optional	No Outputs 1 x 4-20mA/1 x Relay
Stack/Duct Connection	1 1/2" BSP (female)
Enclosure Weight	1.8kg
Enclosure Temperature Rating	-25°C to +70°C
Enclosure Rating	IP65
Sensor Enclosure Material	Die-cast Aluminium (epoxy-coated)
No Air Purge (standard) Air Purge (optional)	

Order Codes

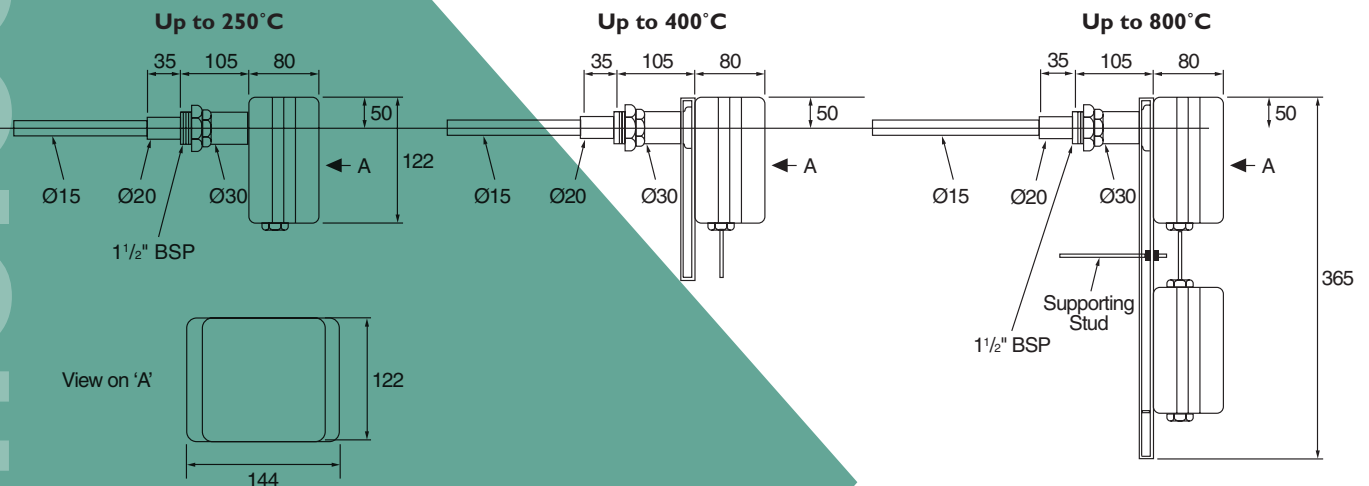

Optional Components

Component	Purpose	Specification	Size (mm)
Cable	Power and communication to sensors from Control Unit	4 core screened (2 for 24V DC, 2 for RS-485 COMMS)	10m per sensor (included). Extendable to > 1000m *
SPUR	Divides cable into 2 branches	3 cable connections	100 w x 66 h x 46 d
AIM (Analogue Input Module)	Input data from external devices (eg for Temp and O ₂)	4 x 4-20 mA inputs 4 x Digital Inputs (contact closure)	160 w x 80 h x 65 d
AOM (Analogue Output Module)	Additional 4-20mA outputs	8 x 4-20 mA outputs	175 w x 80 h x 60 d
ROM (Relay Output Module)	Additional relay outputs	8 x Relays	250 w x 60 h x 80 d
ATEX approved system	For use in dust zones (20, 21 or 22)		
PSU/Repeater	Voltage and signal boost for extended cabling runs with multiple sensors	90 - 260 VAC input (50/60 Hz) 24V DC output	222 w x 125 h x 81 d
220 Sensor	Broken bag detector	Temperature up to 250°C	1 1/2" BSP stack connector

About PCME Ltd

* Can be extended further by use of additional PSU

As a progressive environmental Company, PCME specialises in particulate measurement for industrial processes. With a worldwide reputation for reliability, innovation and technological excellence, the Company produces equipment for concentration, velocity and mass monitoring for regulatory, environmental and process control requirements. A dedicated team of qualified application and sales engineers is always on hand and should be consulted in the selection and usage of the most suitable equipment for any particulate application.



PCME Ltd
Clearview Building, 60 Edison Road
St. Ives, Cambs PE27 3GH UK

Tel: Int +44 (0)1480 468200
Fax: Int +44 (0)1480 463400
E-mail: sales@pcme.co.uk

Contact your national or area sales and service office